



e-ISSN: 2278-8875
p-ISSN: 2320-3765

International Journal of Advanced Research

in Electrical, Electronics and Instrumentation Engineering

Volume 11, Issue 5, May 2022

ISSN INTERNATIONAL
STANDARD
SERIAL
NUMBER
INDIA

Impact Factor: 8.18

☎ 9940 572 462

☑ 6381 907 438

✉ ijareeie@gmail.com

@ www.ijareeie.com



A Survey on Arduino Radar Using Ultrasonic Sensor for Detection and Ranging

Gayatri Sanap, Nikita Makode, Rajeshri Somshetwar, Shital Deshapande

Department of Electronics and Telecommunication, Government College of Engineering, Yavatmal, India

ABSTRACT: RADAR can see things at long distances before humans can see with naked eyes. Radar acts as both an early warning device and tracking device. Radar based systems are used as object detection systems which utilizes electromagnetic waves. This Radar System is controlled via Arduino. Ultrasonic sound sensors are used instead of electromagnetic waves. A servomotor is used to continuously monitor an area of limited range. The project aims at making a RADAR that is cost-efficient and accurate. Due to its insensitivity, it can withstand harsh working conditions such as dirt, dust, rain. The system constantly monitors a limited range and alerts the presence of obstacles if any. If the object is very close to the sensor, then it is alerted using a buzzer and a red LED while if an object is at short distance buzzer and green LED turn on but if the object is out of limited range alert system is off.

KEYWORDS: Object Detection System, Arduino, Ultrasonic Sensor.

I.INTRODUCTION

Target detection is easier when an object is near or easily visible. But the same doesn't stand true when the object is far away or is not visible due to weather conditions. The history of radar actually dates back to the 1880s, when Heinrich Hertz showed that radio waves exist and could be both generated and detected. American physicists Gregory Berit and Merle Tube developed usable radar in 1925, but its use remained limited until shortly before World War II. During the Second World War, technological advances by Germany, England, and the United States resulted in significant improvements to radar in terms of technology, reliability, and power.

The project works on the principle of radar echo effect of the transmitting signal. In this Project we are using the Ultrasonic Sensor to operate by emitting a burst of sound waves in very rapid succession. These sound waves hit the intended target, bounce back to the sensor, and travel at known speed.

An ultrasonic Sensor, radar is much less affected by temperature, improving consistency and accuracy. Servos are small but powerful motors that can be used in a multitude of products ranging from toy helicopters to robots. Arduino controls the servo motor for the direction of the ultrasonic sensor and it moves from 0 degree to 180 degree. Ultrasonic sensor transmits the signal in all directions and if any obstacle that is the target is detected then echo pulse sense. With the help of this echo pulse Arduino program, find out the distance and direction angle of the target. The angle of rotation is displayed on a 16x2 LCD screen. Whenever an obstacle is detected, the buzzer turns on and it is also displayed in the LCD display.[4][5]

II.LITERATURE SURVEY

A. American Association for The Advancement of Science

Heinrich Rudolf Hertz was a brilliant German physicist and experimentalist who demonstrated that the electromagnetic waves predicted by James Clerk Maxwell actually exist. Hertz is also the man whose peers honored by attaching his name to the unit of frequency; a cycle per second is one hertz

Hertz used a simple homemade experimental apparatus, involving an induction coil and a Leyden jar (the original capacitor) to create electromagnetic waves and a spark gap between two brass spheres to detect them. The gaps were difficult to see, and required that the he perform his investigations in a darkened room.

For the sparks are microscopically short, scarcely a hundredth of a millimeter; they last only about a millionth of a second. It almost seems absurd and impossible that they should be visible; but in a perfectly dark room they are visible



to an eye which has been well rested in the dark. Upon this thin thread hangs the success of our undertaking,” said Hertz.

In later experiments, he was able to calculate the speed of the radio waves he created, and found it to be the same as the speed of light. [3]

B. EUSAR 2002, 98 Years of RADAR Principle: Inventor Christian Hansmeyer, Hansmeyer Memorial Speech in the Town Hall of Cologne.

Christian Hansmeyer was a German inventor, physicist and entrepreneur. He is often credited with the invention of radar, although his apparatus, called the “Telemobilscope”, could not directly measure distance to a target. The Telemobilscope was, however, the first patented device using radio waves for detecting the presence of distant objects like ships.

First Patent – Telemobilscope : Hulsmeier filed his patent with the German title in the succeeding echoing patent called, Hertzian-wave Projecting and Receiving Apparatus Adapted to Indicate or Give Warning of the Presence of a Metallic Body, such as a ship or a Train in the line of Projection of such waves.

Plan Position Indicator: Hansmeyer invented an electro-mechanical device to transmit the azimuth angle to pontoon bridge, as it was too difficult to read off the azimuth direction of a detected target on deck. He called it as “Kompas” was a predecessor of the later PPI, the Plan Position Indicator.

Patent: Ranging: Hansmeyer recognized that it would be of great interest to determine direction of the target along with the distance and called it as “Ranging”, in the abbreviation as “RADAR”. Christian Hansmeyer was the first who demonstrated and patented the core of radar principle, namely to detect distant objects by the reflection of electromagnetic waves. [1]

III.METHODOLOGY

Arduino is a free open-source microcontroller. Having input and output digital and analog pins, which enables it to get interfaced with different components. We have interfaced Ultrasonic sensor which is like the heart of the radar. Then to display output LCD (16*2 module). It can be operated in read/write mode. For our purpose we have operated it at write mode. It has enabled pin which indicates as acknowledgement.

Arduino is a free open-source microcontroller. Having input and output digital and analog pins, which enables it to get interfaced with different components. We have interfaced Ultrasonic sensor which is like the heart of the radar. Then to display output LCD (16*2 module). It can be operated in read/write mode. For our purpose we have operated it at write mode. It has enabled pin which indicates as acknowledgement.

Arduino controls the servo motor in angle between 0 to 180 degrees therefore covering the radar range. On this servo motor we are mounting the Ultrasonic sensor. The LED’s and a buzzer are used for the indication of the obstacle.

A. HARDWARE AND SOFTWARE COMPONENTS REQUIRED

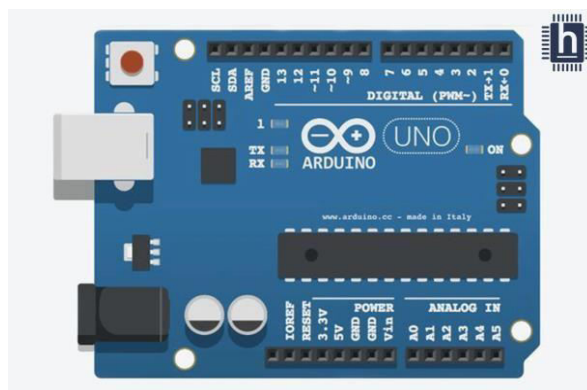

Fig. 1. Arduino UNO



1. **Arduino UNO:** The Arduino Uno is an open-source microcontroller board. The board is equipped with sets of digital and analog input/output (I/O) pins that can be interfaced to other circuits. The board has 14 digital I/O pins (six capable of PWM output), 6 analog I/O pins, and is programmable with the Arduino IDE (Integrated Development Environment), via a type B USB cable.

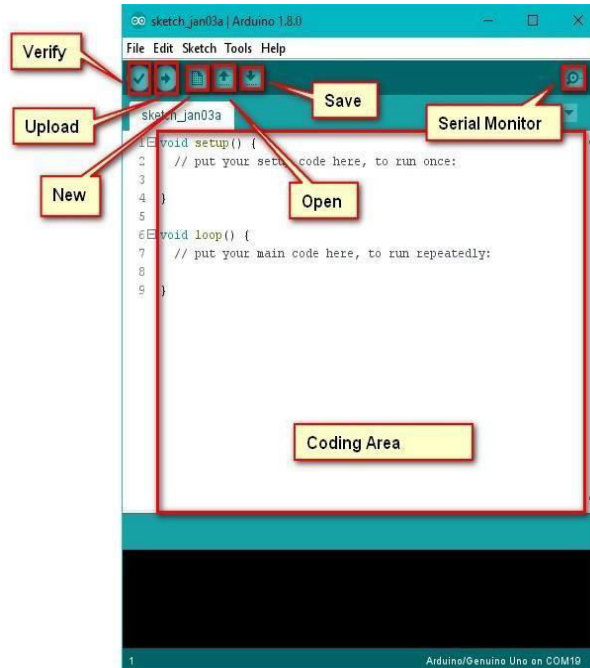

Fig. 2. Arduino Software (IDE)

2. **Arduino Software (IDE):** The open-source Arduino Software (IDE - Integrated Development Environment) is a cross platform application that is written in functions from C and C++. This software can be used with any Arduino compatible board which makes it easy to write code and upload it to the board.

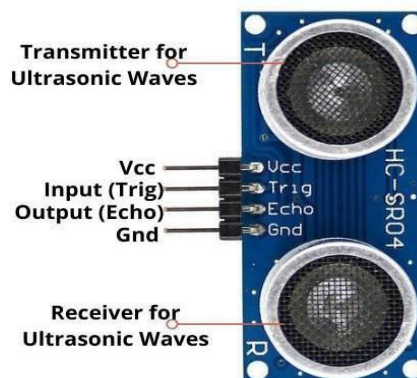

Fig. 3. HC-S304Ultrasonic Sensor

3. **Ultrasonic Sensor HC-S304:** The ultrasonic sensor works on the same principles as a radar system. An ultrasonic sensor can convert electrical energy into acoustic waves and vice versa. The acoustic wave signal is an ultrasonic wave traveling at a frequency above 18 kHz and HC SR04 ultrasonic sensor generates ultrasonic waves at 40 kHz frequency. An ultrasonic sensor is an electronic device that measures the distance of a target object by emitting ultrasonic sound waves, and converts the reflected sound into an electrical signal. Ultrasonic waves travel faster than



the speed of audible sound. The sensor measures the time it takes between the emission of the sound by the transmitter to its contact with the receiver.



Fig. 4. SG-90 Servo Motor

4. Servo Motor: A servo motor is a rotary actuator or a motor that allows for a precise control in terms of the angular position, acceleration, and velocity. Basically, it has certain capabilities that a regular motor does not have. Consequently, it makes use of a regular motor and pairs it with a sensor for position feedback. Positional rotation servo motor is the most important servo motor. Hence it is also the most common type of servo motor. The shaft output rotates in about 180 degrees. Additionally, it includes physical stops located in gear mechanism to stop turning outside these limits to guard the rotation sensor.



Fig. 5. LCD (16*2 Module)

5. Liquid Crystal Display: It is a kind of electronic display module. These displays are mainly preferred for multi-segment light-emitting diodes and seven segments. The main benefits of using this module are inexpensive; simply programmable, animations, and there are no limitations for displaying custom characters, special and even animations, etc.



Fig. 6. Buzzer

6. Buzzer: A buzzer is an audio signaling device, which may be mechanical, electromechanical, or piezoelectric. Typical uses of buzzers include alarm devices, timers, and confirmation of user input such as a mouse click or keystroke.



7. Potentiometer (10K): Potentiometer or POT provides variable resistance.
8. Light Emitting Diode (LED): A LED is a semiconductor light source that emits light when current flows through it. It is a special type of PN junction diode. Light is produced when the particles that carry the current combine together within the semiconductor material.
9. Resistor (220 ohms): A resistor is a passive two- terminal electrical component that implements electrical resistance as a circuit element. In electronic circuits, resistors are used to reduce current flow, adjust signal levels, to divide voltages, bias active elements, and terminate transmission lines, among other uses.

IV.FLOWCHART

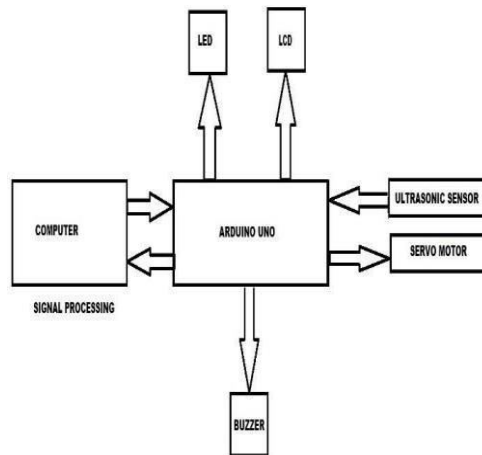

Fig. 7. Block Diagram

The ultrasonic sensor is mounted over the servo motor which rotates 180 degrees covering the limited range to detect the obstacle if present. There are certain conditions to display measured angle and distance on LCD: -

Here D_m - is the distance of object from the sensor.
 D_s - initialized distance referring to which the conditions are checked.

If $d_m < d_s$ become false that means no danger is detected and the LED and buzzer remains off.

But if $d_m < d_s$ become true then the following two conditions are checked: -

If $d_m < d_s/2$ becomes true that means the object is very near to sensor therefore LED 1 i.e., red LED glows and the buzzer rings.

If $d_m < d_s/2$ becomes false that means object is little distant from sensor therefore LED 2 i.e., yellow LED glows and the Buzzer rings.



V.CIRCUIT DIAGRAM

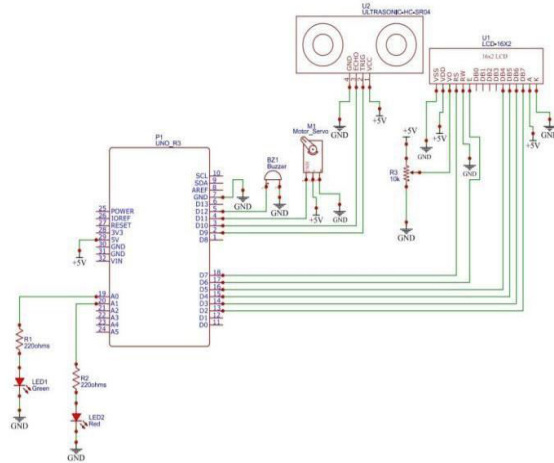

VI.APPLICATIONS

1. Through the wall sensors: It registers motion inside closed spaces.[2]
2. Meteorological Applications: microwave radars used to provide information about distribution, type and intensity of precipitation in atmosphere.
3. UAV Navigations: Unmanned aerial vehicles or drones commonly used ultrasonic sensors for monitoring any objects in the UAV's path and distance from the ground.

VII.FUTURE SCOPE

We have represented a project on Radar using Ultrasonic Sensor for human or object interference in short range. There is a lot future scope of this project as modification with WIFI connection between Arduino and Android can be introduced in order to monitoring through internet. GPS can be introduced for security purpose. The project can be developed and modified according to the rising need and demands.

VIII.CONCLUSIONS

The project on RADAR System has been successfully implemented and the aim is achieved without any deviations. The system estimates the obstacle in its path.

REFERENCES

1. Joachim Ender. Euskara 2002, 98 Years of the RADAR Principle: The Inventor Christian Hansmeyer, Hansmeyer Memorial Speech in the Town` Hall of Cologne. 2002.
2. Yuri ilicin. Technology that sees through the walls. 2015.
3. Ph. D Steven A. Edwards. American Association for The Advancement of Science, Heinrich Hertz and Electromagnetic Radiation. 2012.
4. Research Gate. A Short-Range Radar System “Range Finder”.
5. P. Andrew Karam. Radar Mapping of Solar System. 2020.

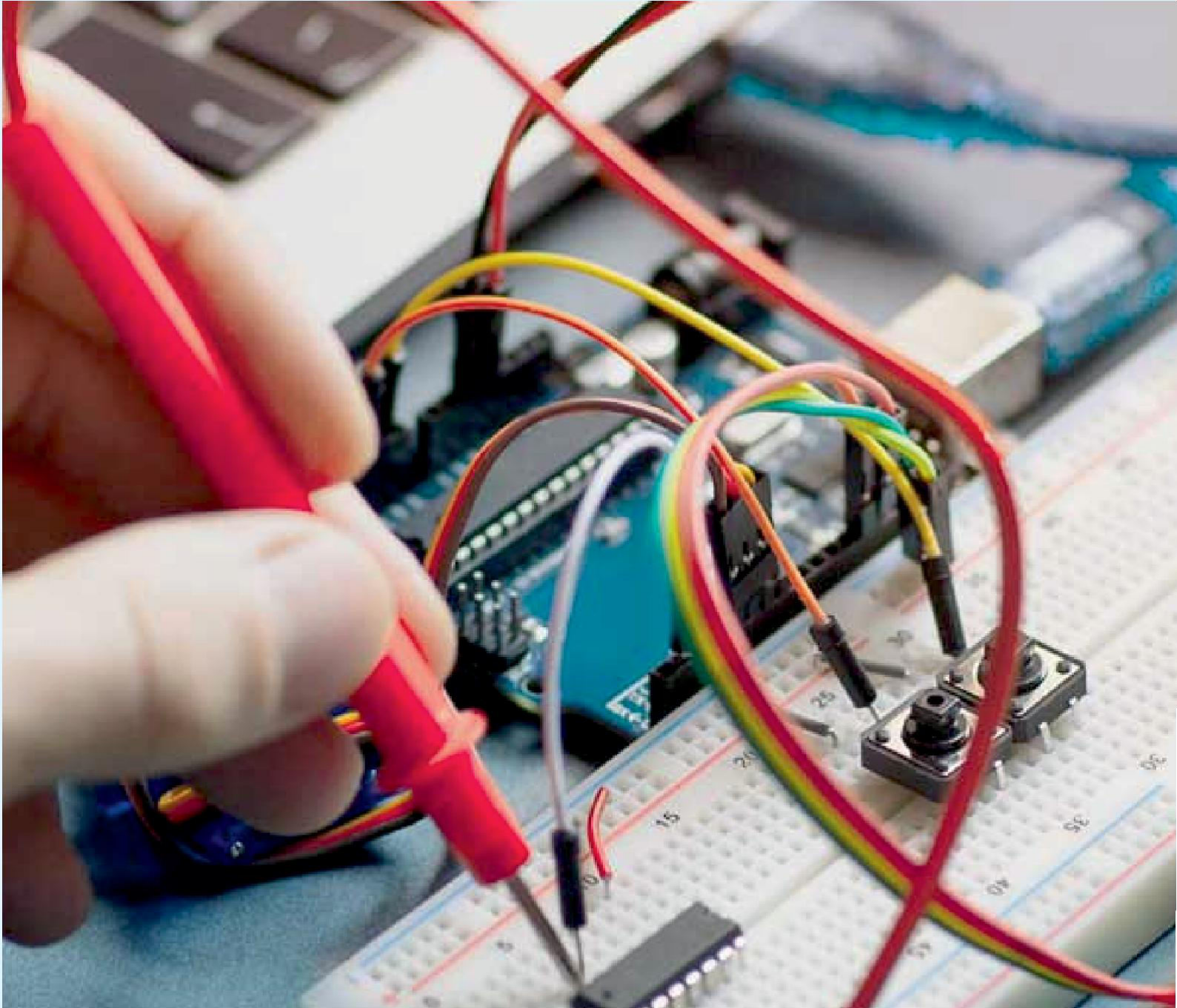

INNO  SPACE
SJIF Scientific Journal Impact Factor

Impact Factor: 8.18



ISSN INTERNATIONAL
STANDARD
SERIAL
NUMBER
INDIA



International Journal of Advanced Research

in Electrical, Electronics and Instrumentation Engineering

 9940 572 462  6381 907 438  ijareeie@gmail.com



www.ijareeie.com

Scan to save the contact details